



EVOKE 2 WHEELCHAIR RANGE

Evoke 2 JNR | Evoke 2 Youth | Evoke 2 | Evoke 2 HD

USER MANUAL



Aspire Evoke 2 JNR



Aspire Evoke 2 Youth



Aspire Evoke 2



Aspire Evoke 2 HD

Congratulations and thank you for choosing an Aspire Wheelchair.

This product has been designed to offer the maximum in comfort, safety and adjustability. Aspire Evoke Wheelchairs are suitable for indoor and outdoor use and are available in a range of sizes.

**It is important that you read this user manual carefully
before using your new wheelchair.**



This product Features the UKCA mark, in compliance with Part II UK MDR 2002 (as amended) Class 1.



This product features the CE mark, in compliance with the Medical Devices Regulation 2002 (as amended) Class 1, and the Medical Device Regulation 2017/745



IMPORTANT: Do not use the Aspire Wheelchair without having first read this user manual

© Aidacare Pty Ltd 2026

No part of this user manual may be copied, distributed, reproduced, scanned, or stored on any electronic database, whether in whole or in part in any form or by any means.

Due care has been taken to ensure all the information contained in this user manual is correct at the time of printing. All measurements, pictures, colours, and weight capacities are to be used as a guide only. We reserve the right to modify the design or appearance of any product displayed in this user manual without prior notice.

TABLE OF CONTENTS

1. Symbols Used in This Manual	4
2. Symbols Used on the Product	4
3. Intended Use	5
4. Product Description	6
5. Warnings	6
6. Product Specifications	7
7. List of Components	8
8. Assembly	9
9. Preliminary Checks	10
10. General Operation	10
11. Adjustments	15
12. Accessories	17
13. Amputee Setting Adjustment	26
14. Troubleshooting	28
15. Care & Maintenance	29
16. Warranty	30
17. Compliance	30
18. Service Maintenance & Customisation	30
19. Recycling Information	31
20. Manufacturer, EU Representative & Importer Details	31

1. SYMBOLS USED IN THIS MANUAL

The symbols below are used throughout this user manual and on the product to identify warnings and important information. It is very important for you to read them and understand them completely.



WARNING! Indicates a potentially hazardous condition/situation. Failure to follow designated procedures can cause either personal injury, component damage or malfunction. On the product, this icon is represented as a black symbol on a white triangle with a black border.



ALWAYS! These actions should be performed as specified. Failure to perform mandatory actions can cause personal injury and/or equipment damage. On the product, this icon is represented as a white infinity symbol on a black dot with a white border.



DO NOT! These actions are prohibited. These actions should not be performed at any time or in any circumstances. Performing a prohibited action can cause personal injury and/or equipment damage. On the product, this icon is represented as a white symbol with a black circle and black slash.

2. SYMBOLS USED ON THE PRODUCT

aspire™ EVOKE 2 WHEELCHAIR

MWS449500 SN

AUSTRALIA | Aidacare Pty Ltd | ABN 40 134 398 833
Building 3A, 1 Moorebank Avenue, Moorebank NSW 2170
1300 133 120 | product@aidacare.com.au

UNITED KINGDOM | Aidacare Ltd | Registration 13785408
Arcadia House, Maritime Walk, Ocean Village, Southampton
SO14 3TL 01622 541235 | info@aidacare.co.uk

MADE IN PRC It is recommended that you have this product serviced every 12 months.

European Healthcare & Device Solutions (Ireland) Ltd.
Stratton House, Bishopstown Road,
Cork T12 Y9TC Ireland
info@europeandevicesolutions.eu

EC REP

CE i ! SWL 120KG

UK CA MD

Please note: Stickers are not shown to scale.

- | | |
|---|--|
| <p># Product Code</p> <p>SN Serial Number</p> <p>Manufacturer</p> <p>Importer</p> <p>Country of Manufacture</p> <p>EC REP Authorised Representative in EU</p> <p>CE CE Mark</p> | <p>UK CA UKCA Mark</p> <p>SWL 140KG Safe Working Load</p> <p>i Read User Manual</p> <p>! Caution</p> <p>MD Medical Device</p> <p>! Crash Tested to ISO7176-19:2008</p> |
|---|--|

3. INTENDED USE

Aspire Evoke 2 Manual Wheelchair

This product is specifically designed for individuals who, due to a wide variety of reasons, have limited mobility or are unable to walk. This product should be used as a tool to assist with mobility or walking difficulties.

Attendant Propelled Wheelchairs are able to be propelled by an attendant with the push handles. This wheelchair is designed for indoor and limited outdoor use. When used outdoors this wheelchair must remain on sealed, level terrain (examples include but are not limited to shopping centres, medical centres, flat and level footpaths, and environments with accessibility-focused layouts). When using outdoors it is suggested that anti-tip wheels are fitted.

Self Propelled Wheelchairs are able to be propelled by a user with the self-propelling wheels or by an attendant with the push handles. This wheelchair is designed for indoor and limited outdoor use. When used outdoors this wheelchair must remain on sealed, level terrain (examples include but are not limited to shopping centres, medical centres, flat and level footpaths, and environments with accessibility-focused layouts). When using outdoors it is suggested that anti-tip wheels are fitted.



WARNING! This wheelchair is intended to bear the weight of an occupant through its wheels during propulsion and when stationary. It is **NOT** designed to be lifted/carried with an occupant in the seat and doing so may cause serious injury or death.

Aspire Evoke 2 JNR and Youth Manual Wheelchair

This product is specifically designed for children who, due to a wide variety of reasons, have limited mobility or are unable to walk. This product should be used as a tool to assist with mobility or walking difficulties.

Attendant Propelled Wheelchairs are able to be propelled by an attendant with the push handles. This wheelchair is designed for indoor and limited outdoor use. When used outdoors this wheelchair must remain on sealed, level terrain (examples include but are not limited to shopping centres, medical centres, flat and level footpaths, and environments with accessibility-focused layouts). When using outdoors it is suggested that anti-tip wheels are fitted.

Self Propelled Wheelchairs are able to be propelled by a user with the self-propelling wheels or by an attendant with the push handles. This wheelchair is designed for indoor and limited outdoor use. When used outdoors this wheelchair must remain on sealed, level terrain (examples include but are not limited to shopping centres, medical centres, flat and level footpaths, and environments with accessibility-focused layouts). When using outdoors it is suggested that anti-tip wheels are fitted.



WARNING! This wheelchair is intended to bear the weight of an occupant through its wheels during propulsion and when stationary. It is **NOT** designed to be lifted/carried with an occupant in the seat and doing so may cause serious injury or death.

4. PRODUCT DESCRIPTION

Aspire Evoke 2 Manual Wheelchair

The Aspire Evoke 2 Manual Wheelchair is a lightweight four wheel wheelchair with a cross folding frame. The product is made of aircraft grade aluminium, ensuring strength, durability and easy movement. This wheelchair offers enhanced manoeuvrability and stability, a wide size range and leading adjustability for a customised fit. It is equipped with a fabric seat and back, seat cushion, push handles, large 24 inch rear self-propelling quick release wheels and removable swing away legrests. A large range of accessories can be fitted to the Aspire Evoke 2 Manual Wheelchair to improve its overall performance.

Aspire Evoke 2 JNR and Youth Manual Wheelchair

The Aspire Evoke 2 JNR and Youth Manual Wheelchair is a lightweight four wheel wheelchair with a cross folding frame. The product is made of aluminium, ensuring strength durability and easy movement. This wheelchair offers enhanced manoeuvrability and stability, a wide size range and leading adjustability for a customised fit. It is equipped with a fabric seat and back, seat cushion, push handles, medium 20 inch rear self-propelling quick release wheels and removable swing away legrests. A large range of accessories can be fitted to the Aspire Evoke 2 JNR and Youth Manual Wheelchair to improve its overall performance.

5. WARNINGS

MAXIMUM WEIGHT CAPACITY – 150kg / 23.6st – 350 – 500mm / 13.7" – 19.6" SEAT WIDTHS

MAXIMUM WEIGHT CAPACITY – 190kg / 29.9st – 570 – 610mm / 22.4" – 24" SEAT WIDTHS



DO NOT exceed maximum user weight. This weight limit includes any accessories, shopping or other personal items that may be carried on the chair. The maximum weight capacity is defined with respect to a typical body shape, where body mass is evenly distributed. Users with dysmorphic body shapes or amputees should be assessed by an accredited healthcare professional prior to choosing/using this wheelchair.



DO NOT stand on the foot plates as the wheelchair may tip forwards. The foot plates are not designed to be a weight bearing surface.



DO NOT use the wheelchair on escalators, even if accompanied by an attendant.



DO NOT use the wheelchair on escalators, even if accompanied by an attendant.



ALWAYS use push rims to bring the wheelchair to a stop. **DO NOT** use the brakes to stop a moving wheelchair.



WARNING! Pay attention to your fingers when folding or opening the wheelchair and when self-propelling the chair with hands in close proximity to wheel spokes.

6. PRODUCT SPECIFICATIONS

ASPIRE EVOKE 2 MANUAL WHEELCHAIR

MODEL	SEAT WIDTH (mm / inches)	OVERALL WIDTH (mm / inches)	SEAT DEPTH (mm / inches)	SEAT HEIGHT (mm / inches)	BACKREST HEIGHT (mm / inches)	ARMREST HEIGHT (mm / inches)	MINIMUM CHAIR WEIGHT (kg / lb)	SWL (kg / st)
EVOKE 2	350	560	375 – 450	450 – 500	430 – 490	210 – 230	14.8 kg	150 kg
	14"	22"	11.8" – 17.7"	17.1" – 19.6"	16.9" – 19.2"	8.26" – 9"	32.6lbs	23.6st
	400	610	375 – 450	450 – 500	430 – 490	210 – 230	14.9 kg	150kg
	16"	24"	11.8" – 17.7"	17.1" – 19.6"	16.9" – 19.2"	8.26" – 9"	32.8lbs	23.6st
	450	660	375 – 450	450 – 500	430 – 490	210 – 230	15.0 kg	150 kg
	18"	25.9"	11.8" – 17.7"	17.1" – 19.6"	16.9" – 19.2"	8.26" – 9"	33lbs	23.6st
	500	710	400 – 550	450 – 500	430 – 490	210 – 230	15.1 kg	150 kg
	20"	27.9"	15.7" – 21.6"	17.1" – 19.6"	16.9" – 19.2"	8.26" – 9"	33.2lbs	23.6st
EVOKE 2 HD	570	780	400 – 550	450 – 500	430 – 490	210 – 230	16.0 kg	190 kg
	22"	30.7"	15.7" – 21.6"	17.1" – 19.6"	16.9" – 19.2"	8.26" – 9"	35.2lbs	29.9st
	610	820	400 – 550	450 – 500	430 – 490	210 – 230	16.2 kg	190 kg
	24"	32.2"	15.7" – 21.6"	17.1" – 19.6"	16.9" – 19.2"	8.26" – 9"	35.7lbs	29.9st

ASPIRE EVOKE 2 JNR AND EVOKE 2 YOUTH MANUAL WHEELCHAIR

MODEL	SEAT WIDTH (mm / inches)	OVERALL WIDTH (mm / inches)	SEAT DEPTH (mm / inches)	SEAT HEIGHT (mm / inches)	BACKREST HEIGHT (mm / inches)	ARMREST HEIGHT (mm / inches)	MINIMUM CHAIR WEIGHT (kg / lb)	SWL (kg / st)
EVOKE 2 JNR	300	510	300 – 450	410 – 450	430 – 490	210 – 230	14kg	150kg
	12"	20"	11.8" – 17.7"	16.1" – 17.7"	16.9" – 19.2"	8.2" – 9"	30.8lbs	23.6st
EVOKE 2 YOUTH	350	560	300 – 450	440 – 480	430 – 490	205 – 225	14.8kg	150kg
	13.8"	22.1"	13.8" – 16.7"	17.3" – 18.9"	16.9" – 19.3"	8" – 8.7"	32.6lbs	23.6st

7. LIST OF COMPONENTS

ASPIRE EVOKE 2 MANUAL WHEELCHAIR



1	Rear Wheels
2	Quick Release Axles
3	Armrests
4	Footrests
5	Height Adjustable Castor Fork
6	Front Castor Wheel
7	Foot Plate with Heel Loop
8	Attendant Hand Grips
9	Hand Brakes
10	Cross Bar
11	Anti Tippers

ASPIRE EVOKE 2 JNR AND YOUTH MANUAL WHEELCHAIR



1	Rear Wheels
2	Quick Release Axles
3	Armrests
4	Footrests
5	Height Adjustable Castor Fork
6	Front Castor Wheel
7	Foot Plate with Heel Loop
8	Attendant Hand Grips
9	Hand Brakes
10	Cross Bar
11	Anti Tippers

8. ASSEMBLY

BOX CONTAINS

Wheelchair frame fitted with rear wheels

- Wheelchair
- Left Legrest
- Right Legrest
- Allen Keys (4mm, 5mm)
- User Manual
- Seat Cushion



When opening the carton, ensure it is done in a safe and careful manner. **DO NOT USE** a box cutter or sharp implement as this may damage the product. For WH&S purposes, lay the carton on its side with the top of the carton open and slide the plastic bag out containing the wheelchair.

1 Place the wheelchair on levelled ground. Then push down on the side rails of the seat until flat.

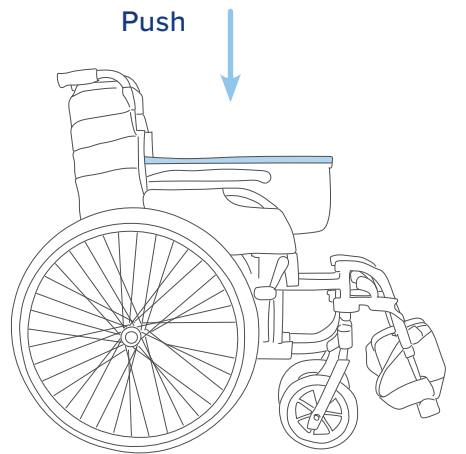

2 Secure the cushion onto the base.

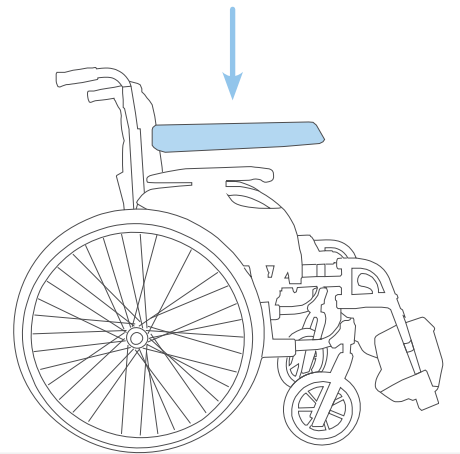

3 Wheelchairs come with a left and right legrest.

1. Insert the legrest into the corresponding receiver at a 90° angle (as shown).
2. Twist and hold the latch, simultaneously rotating the legrest towards the centre until it clicks into place. Repeat for the other side.

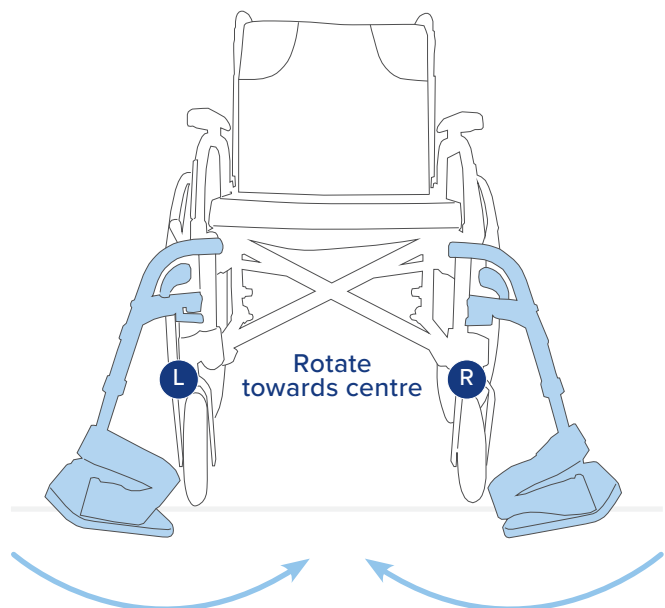

9. PRELIMINARY CHECKS

After assembling the wheelchair, these checks should be completed prior to initial use:

1. Check that the seating surface is locked into place, creating a flat support surface.
2. Check that rear wheels are locked in place and that quick release axle is not loose.
3. Check that rear brakes engage and disengage.
4. If fitted with accessories, ensure that they are secure and locked in place.

10. GENERAL OPERATION

10.1 GENERAL OPERATION

It is very important that this wheelchair is used under guidance from all warnings or hazards listed in this product user manual. Key safety measures should be taken by both users and attendants when using this wheelchair:

- Avoid quick direction changes.
- Ensure your wheelchair is used on surfaces intended for its use.
- Ensure an attendant is available to assist at all times.

10.2 LIFTING THE WHEELCHAIR

To fold your chair correctly follow the 'ASSEMBLY' instructions in reverse **3**, **2**, **1**.

Then, use the carry handle on the seating surface to safely lift the wheelchair.



DO NOT lift the wheelchair with an occupant in the seat. This lifting guide is for safe handling of the wheelchair only.



WARNING

WARNING! DO NOT lift the wheelchair by holding it by the legrests or the armrests! Fold-up the legrests prior to lifting the chair.

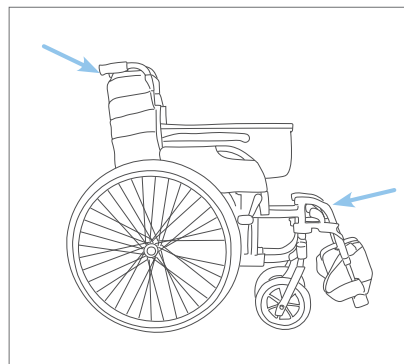

10.3 TRANSPORTING THE WHEELCHAIR (WITHOUT OCCUPANT)

To transport this chair in a motor vehicle it is suggested that the backrest, seat and legrests are folded as per the "Lifting the Wheelchair" instructions above. This will help reduce the overall chair size in order to fit into the rear boot or backseat of a standard motor vehicle.

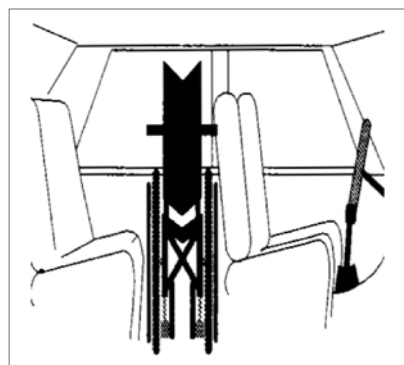

10.4 MOVING WHEELCHAIR UP A KERB OR SINGLE STEP (WITH AN ATTENDANT)

1. Push the wheelchair up to the kerb **FEET FIRST**.
2. The attendant should push down on the rear foot peg to slightly incline the chair.
DO NOT tilt the chair back with the push handles.
3. Once the front wheels are firmly on the ground above the kerb, the rear wheels should be pushed against the kerb to propel the entire chair to rest above the kerb.



WARNING! This should only ever be done with an attendant and not performed by a user on their own. It is very important the above steps are followed to prevent injury to both the user and the attendant.

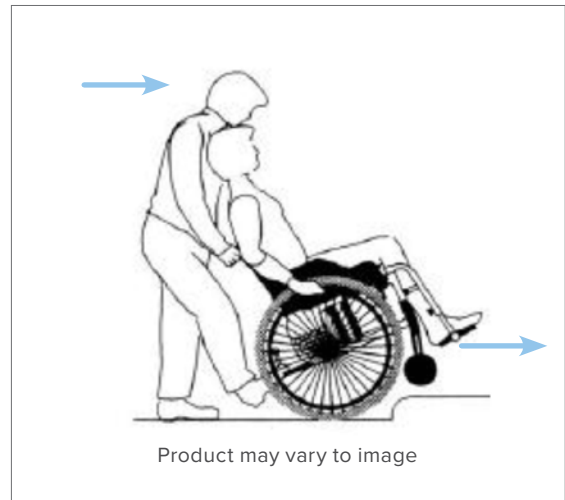

10.5 MOVING WHEELCHAIR DOWN A KERB OR SINGLE STEP (WITH AN ATTENDANT)

1. Reverse the wheelchair up to the kerb **FEET LAST**.
2. The attendant should check for cars or obstructions prior to commencing the descent.
3. The attendant should slowly lower the rear wheels down to the road surface, ensuring not to tip the chair.
4. Once the rear wheels are firmly on the road surface, the front wheels should be slowly lowered onto the road surface.



WARNING! This should only ever be done with an attendant and not performed by a user on their own. It is very important the above steps are followed to prevent injury to both the user and the attendant.



10.6 OTHER IMPORTANT WARNINGS



Warning! Slopped or uneven terrain

This wheelchair is designed for use on flat-level surfaces. If encountering sloped or uneven terrain an alternative route should be sought. If impossible a carer should always be present, anti tippers should be installed and the attendant brakes should be used to control speed and ensure the wheelchair to continues straight forward until reaching flat ground.



Warning! Maintaining stationary position

When not propelling the wheelchair the brakes should be applied in the locked position at all times.



WARNING

Warning! Protecting hands when self-propelling

When slowing or braking the wheelchair using the self-propelling hand rims, heat can be created via friction. To protect the skin integrity of the hands, it is strongly suggested that the user wear wheelchair gloves.



WARNING

WARNING! DO NOT travels down kerbs or single steps without an attendant carer

NEVER attempt to transit down multiple steps with or without an attendant carer.



WARNING

WARNING! When self-propelling the wheelchair, it is strongly suggested that anti-tip wheels are fitted. If anti-tip wheels are in the raised position or not fitted to the chair an attendant carer should stand behind the wheelchair holding the handles.

SAFE USE

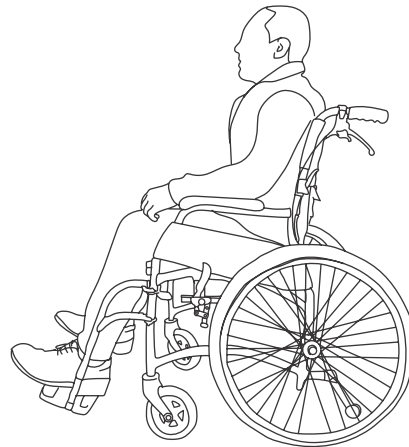
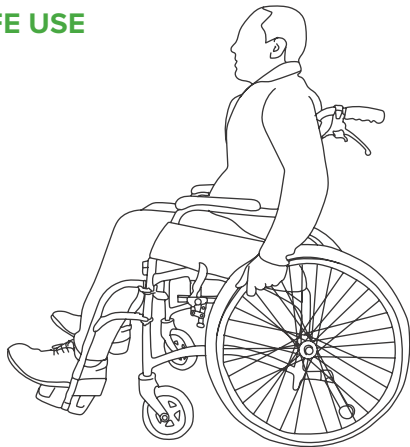

UNSAFE USE

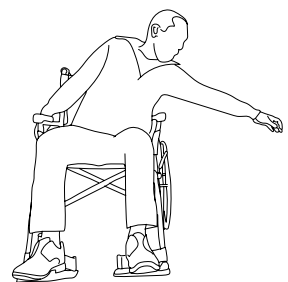
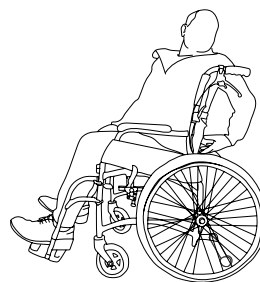
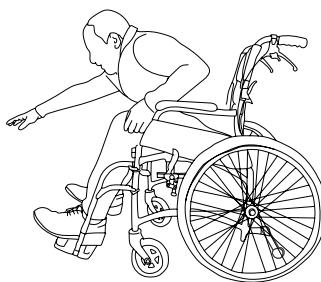
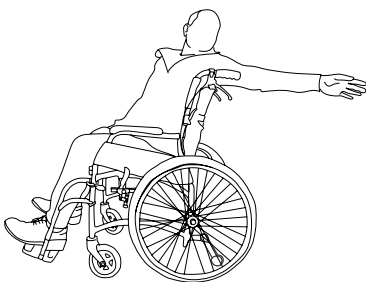

WARNING

Warning! Avoid reaching from within the wheelchair

To ensure the upright stability of the wheelchair, never reach for objects as this changes the centre of mass and may cause the chair to tip over in the direction of reaching. This warning relates to reaching in any direction outside the perimeter of the wheelchair.

10.6 TRANSPORTING THE WHEELCHAIR (WITH AN OCCUPANT)

Aspire Evoke 2 & Evoke 2 JNR wheelchairs are compliant to ISO7176-19:2008 & AS/NZS 3696.19t (Wheelchairs wheeled mobility devices for use as seats in motor vehicles). These are approved to be used in compliant vehicles when fitted with a headrest. (See page 23 – Deluxe Headrest).

To secure Aspire Evoke 2 & Evoke 2 JNR wheelchairs, the below steps must be followed:

1. Identify tie down points (4 in total) on wheelchair frame, these are identified with a tie down logo.

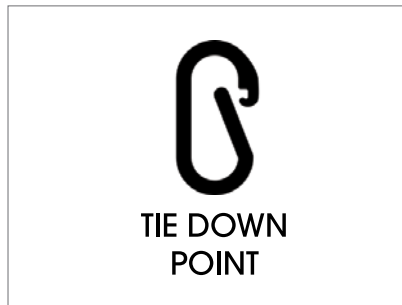

2. Apply wheelchair brakes. (Both sides)

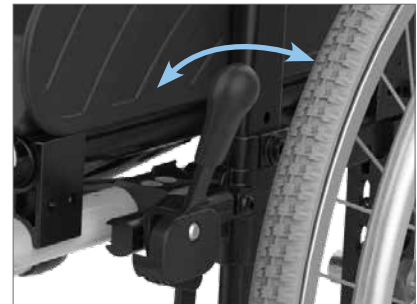

3. Secure all four tie down points ensuring the chair is firmly secured to the vehicle not allowing any movement whilst being transported.

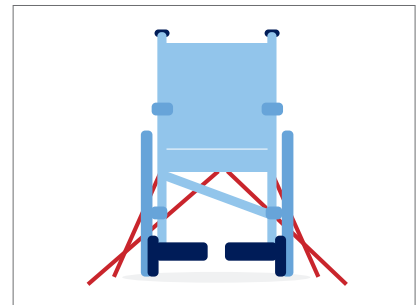

4. Fasten seat belt over the occupants shoulder, passing over their lap, down beside the rear wheel and locking into place in the buckle located on the floor of the vehicle.





WARNING! DO NOT transport an occupant in the wheelchair if the above process is not correctly followed. It is imperative that these steps are completed in order to ensure user safety. The wheelchair is to always be facing the same direction of seats within the vehicle, not to the side or backwards.

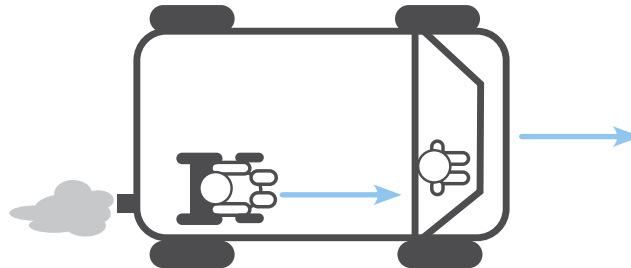

10.7 USING THE WHEELCHAIR BRAKES

Aspire Evoke 2 Manual Wheelchairs have locking brakes to ensure no movement occurs when the wheelchair is in a stationary position.

- 1 To engage brakes, push forward on the brake lever until firmly locked in place.
- 2 To disengage brakes, pull back on the brake lever until unlocked.

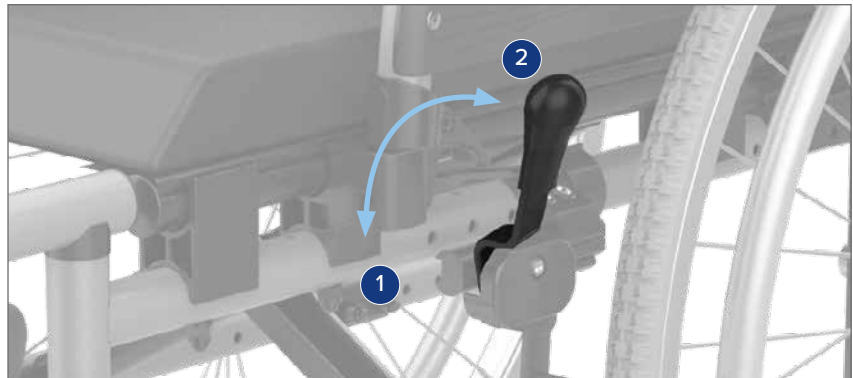

WARNING! Brakes should always be locked when leaving a user unattended in the wheelchair.

10.8 QUICK RELEASE WHEELS

If the rear wheels need to be removed for repair or replacement, quick release axles are fitted to assist.

- 1 To detach the rear wheel from the frame, press & hold the release button and remove the wheel from the frame.
- 2 To attach wheel, reverse step 1.



WARNING! Ensure quick release axles are mounted correctly and locked in place prior to seating a user.



11. ADJUSTMENTS

Aspire Evoke 2 & Evoke 2 JNR Manual Wheelchairs have multiple adjustment points to ensure maximum comfort for users. It is very important that the below steps are followed when adjusting the wheelchair to ensure maximum safety.

11.1 BACKREST HEIGHT ADJUSTMENT

- 1 Peel back upholstery in the lower edge of the backrest cane to reveal two bolt heads.
- 2 Remove 8 bolts (4 x each side) and reposition canes as required.
- 3 Tighten bolts and reattach upholstery.



11.2 BACKREST TENSION ADJUSTMENT

- 1 Peel back upholstery to reveal Velcro adjustment straps.
- 2 Reposition straps to desired position and reapply upholstery securing in place with Velcro.

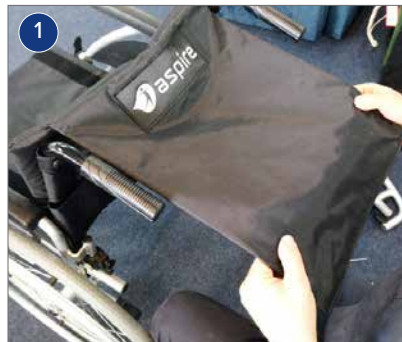

11.3 SEAT DEPTH AND REAR WHEEL ADJUSTMENT

- 1 Remove all bolts as shown and move backrest receiver bracket to the desired seat depth.
- 2 To adjust rear wheel position and height, the axle mount and receiver can be adjusted as shown. Once at the desired position, ensure all hardware is tightened securely.

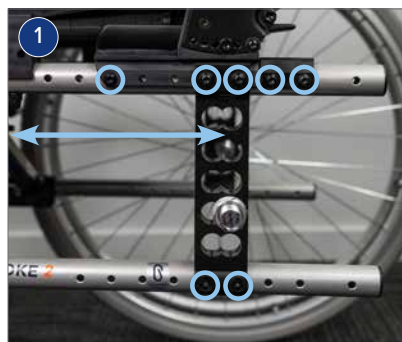

NOTE: Ensure the rear wheels are located in symmetrical positions on both sides of the chair to maintain stability.

11.4 BACKREST ANGLE ADJUSTMENT

- 1 Using the Allen key supplied, loosen the screws on either side of the backrest plate.
- 2 Reposition backrest into the desired position and fasten screws in place.



11.5 FRONT CASTOR HEIGHT ADJUSTMENT

- 1 Using the Allen key supplied, loosen the bolts and remove the centre pin.
- 2 Reposition to the desired height, reposition centre pin and fasten with bolts.

NOTE: Ensure the front castors are located in symmetrical positions on both sides of the chair to maintain stability.



11.6 FRONT CASTOR FORK ANGLE ADJUSTMENT

- 1 Using the Allen key supplied, remove both mounting screws.
- 2 Fork can be re positioned to 4 pre-determined angle and fasten with screws.

NOTE: Ensure the front castors are located in symmetrical positions on both sides of the chair to maintain stability.

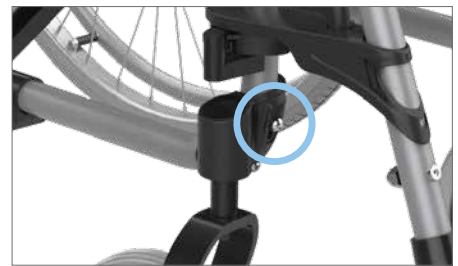

11.7 FOOTREST HEIGHT ADJUSTMENT

- 1 Using the Allen key supplied, loosen the bolt on the side of the footrest.
- 2 Reposition the height of the footrest and fasten in place with the bolt.



11.8 FOOTREST ANGLE ADJUSTMENT

- 1 Using the allen key supplied, loosen the bolt on the side of the footrest.
- 2 Reposition the angle of the footrest and fasten in place with the bolt.



11.9 ANTI-TIP WHEELS

Anti-tip bars ensure a chair will not tip when over tilted by a user or an attendant. These are included with the item as standard and should always be installed.

- 1 Remove rear foot pegs, slide on anti-tip bars and lock in place.
- 2 The anti-tip wheel height range is adjustable for improved mobility during carer transportation.

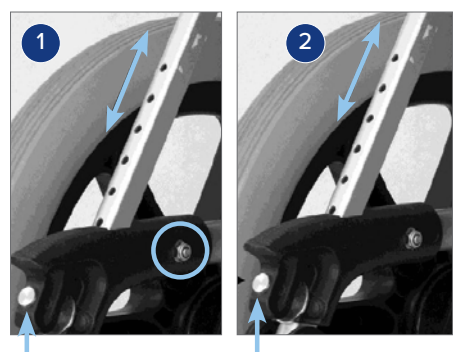

12. ACCESSORIES

Aspire Evoke 2 and Evoke 2 JNR Manual Wheelchairs are compatible with a large range of accessories to improve product performance.

12.1 ATTENDANT PROPELLED CONVERSION KIT



WARNING! Impact on Safe Working Load: When using the attendant conversion kit options, please note that the Safe Working Load (SWL) will be reduced to 120kg. This limitation is critical for ensuring the safety and functionality of the equipment.

Attendant Propelled Conversion Kit (Includes Brakes and Wheels) – WCA848594

Components included in the kit

- 2 x 12" wheels
- 2 x T-brackets
- 2 x Attendant brake levers
- 2 x Brake assemblies with hardware
- 1 x New SWL sticker
- 1 x Manufacturer's Identification Sticker

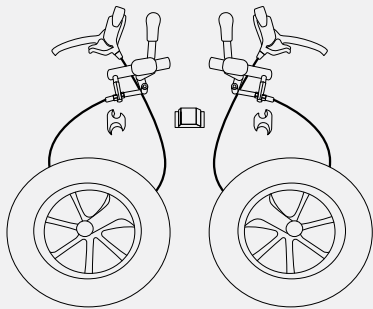

Tools required for assembly

- 24mm Spanner
- 10mm Spanner
- 4mm Allen Key
- 5mm Allen Key

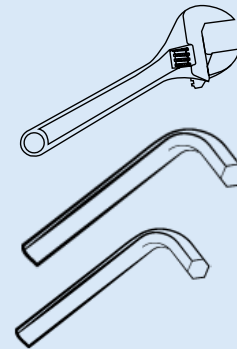

1. Remove the 24" wheel
 - a. Press the axle cap in to release the axle and wheel from the wheelchair
2. Remove the Axle receiver for the 24" wheels from the upright mounting bracket.
 - a. Use the 24mm spanner to unscrew the nut on both sides
 - b. Remove the axle receiver
 - c. Keep it with the 24" wheels, axle, and axle receiver in a safe place (should you wish to convert the wheelchair to Self Propelled again in future)



3. Assemble the T-bracket and attach to frame

- a. Line the T-bracket up with the holes next to the upright mounting bracket
- b. Screw the T-bracket into place using the 10mm spanner and 4mm Allen key



4. Attach the 12" wheels

- a. Mount the 12" wheel with axle
- b. The ball bearing on the end of the axle will lock the wheel into place



5. Assemble the attendant brakes

- a. Place the brake mount around the wheelchair frame in front of the rear wheels, making sure that the brake is close to the wheels, screw the mount in using the 5mm Allen key
- b. Attach the attendant brake lever to the handlebars of the wheelchair and screw them using 4mm Allen key



6. Replace current Manufacturer's identification sticker and SWL sticker with the new stickers provided in the kit as shown below.

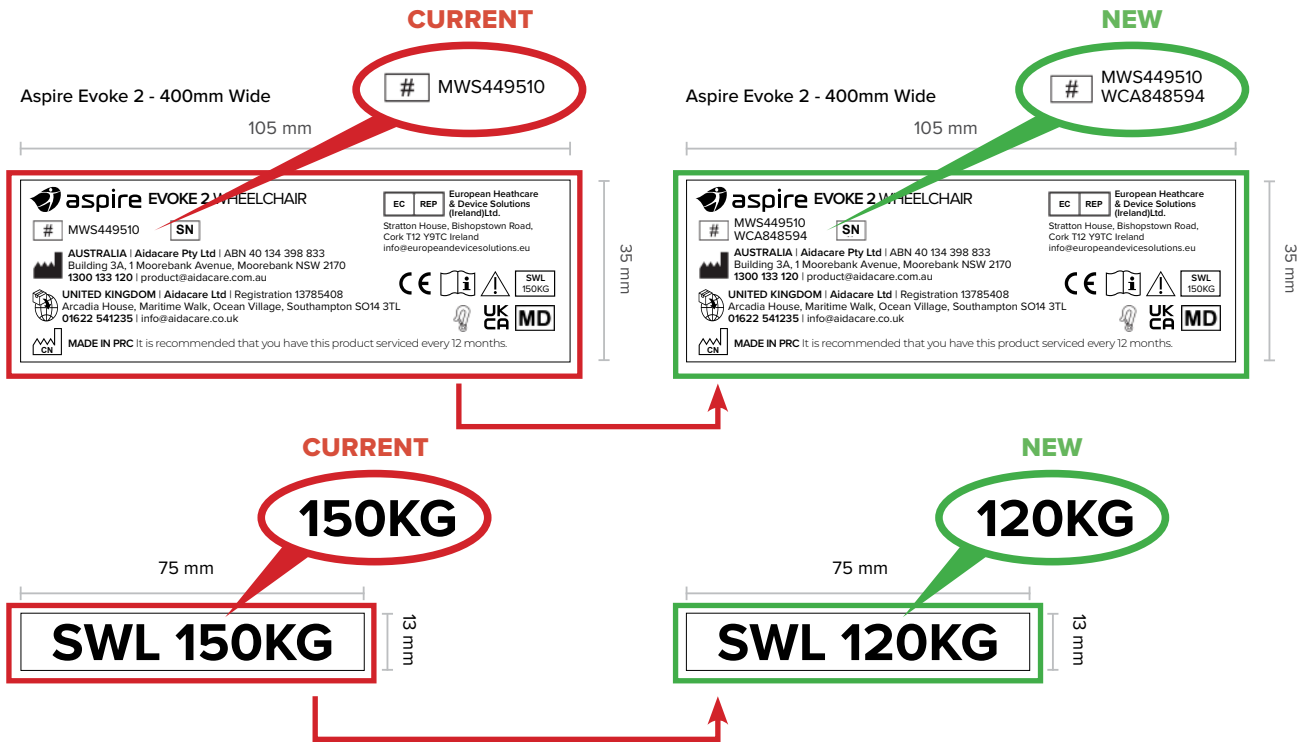

7. Follow the same instructions for the other side and enjoy your attendant propelled wheelchair



12.2 ELEVATING LEGRESTS

Elevating legrests allow for a users legs to be reclined for comfort and pressure care.

- 1 Elevating legrests connect to the wheelchair frame using the same method as standard legrests (see page 8, step 3).
- 2 To adjust legrest angle, press and hold the release button (2) and lift or lower the footplate as required.

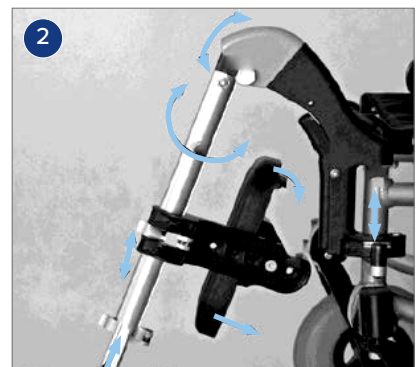
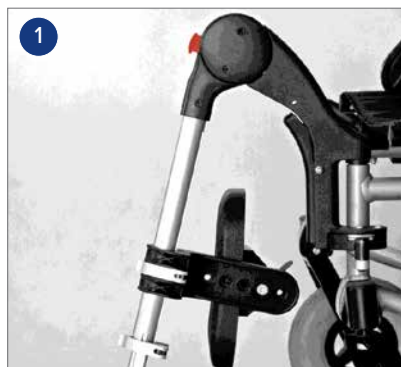

12.3 AMPUTEE/STUMP SUPPORT

Stump supports / amputee supports connect easily on to the legrest receiver to ensure amputee users can sit in comfort offering a contoured and extended support surface.

- 1 Insert the Stump Support into the top of the frame legrest receivers.
- 2 Adjust the height or angle of the stump support by using the hand fastening lever.



12.4 BRAKE EXTENSION LEVER

To assist in a user activating the brakes, an extended brake lever can be fitted.

- 1 Remove the existing brake lever by unscrewing the mounting hardware.
- 2 Mount the extended brake lever by screwing the mounting hardware firmly in place.

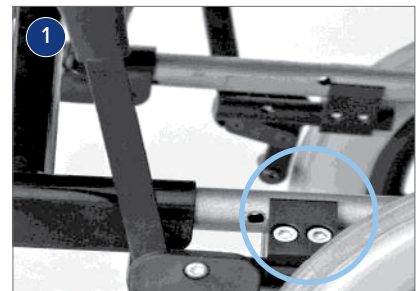

12.5 IV POLE

To facilitate Intravenous infusion, IV Poles can be mounted to the wheelchair.

- 1 Attach the IV pole clamp to the top part of the back cane.
- 2 Tighten the clamp so it is secure.
- 3 Insert the IV pole into the clamp until it is fully in place.
- 4 Tighten the hand bolt to lock the IV pole in position.



12.6 LAP/SEAT BELT

For extra safety when manoeuvring a user, a lap belt is available. To install the lap belt, please follow below steps

Tools required for assembly

- 10mm Spanner
- 5mm Allen Key

- 1 Remove the rear self propelling wheel using quick release.
- 2 Align the eyelet of the lap belt with the slots available on the rear of the chair top frame, right after the backrest cane. Ensure that the raised side of the eyelet is facing outwards and that the eyelet is positioned on the same slot on both sides.
- 3 Bolt is passed through the eyelet in the end of the seatbelt.
- 4 Bolt is then refastened in place.
- 5 Repeat on the other side and then reattach wheels.



12.7 OXYGEN BOTTLE HOLDER

For users who require an oxygen source, the oxygen bottle holder mounts simply to the rear of the chair frame.

- 1 Align oxygen bottle holder with frame mounting holes and fasten in place with bolts provided.
- 2 Insert oxygen bottle ensuring all tubing and regulator are clear of moving parts, such as rear wheels.



12.8 HEIGHT ADJUSTABLE ARMRESTS

For additional positioning requirements, height and depth adjustable armrests can easily be mounted to the wheelchair.

- 1 To adjust the height of the armrest, press and hold the button then raise and lower the armrest pad.
- 2 To adjust armrest depth undo the bolts connecting the pad to the armrest frame, position as required and re-fasten securely.



12.9 GUTTER ARMRESTS

For additional comfort, gutter armrest pads can be mounted to existing armrests:

- 1 Remove standard armrest pad by unscrewing from underneath all bolts.
- 2 Line up gutter armrests and fix in place with bolts.

Note: Side transfers are not possible when gutter armrests are attached

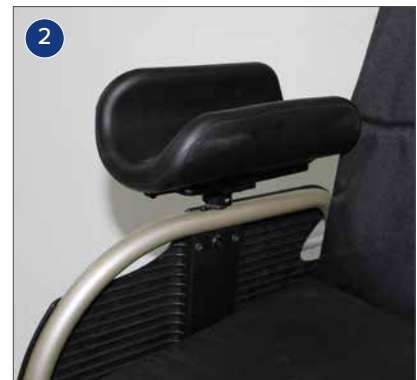

12.10 CONTOURED PADDED OVERLAY

For extra user comfort, contoured padded overlays can be fitted.

- 1 Remove seat cushion.
- 2 Place contoured padded overlay on seating surface ensuring that the seat and back are now covered.
- 3 Fasten seat in place by lining up Velcro strips on seating and backrest surface.
- 4 Fasten back in place by lining up Velcro strips on rear of backrest.

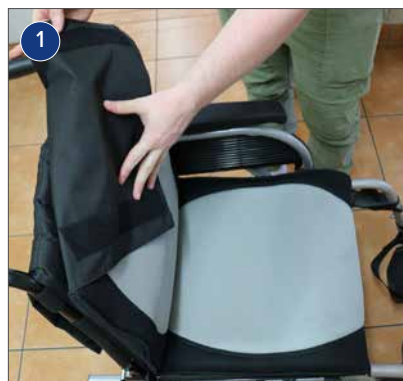

12.11 DELUXE HEADREST

For comfort and safe vehicle transportation, the deluxe headrest attachment can be retro-fitted.

- 1 Mount cross bar across rear push handles, fasten in place with locking pin.
- 2 Adjust position of headrest and lock into place with fastening hand wheel.

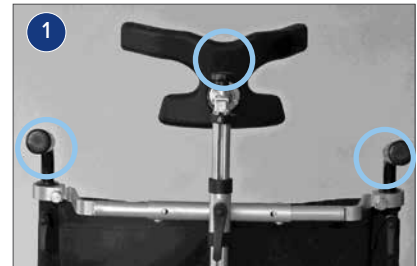

12.12 LATERAL SUPPORT PADS

For additional lateral support and stabilisation, lateral chest supports can be retrofitted.

- 1 Mount bracket to rear backrest cane, fasten in place with bolts.
- 2 To change the angle, loosen the bolts until desired position is reached, lock in place with bolts.

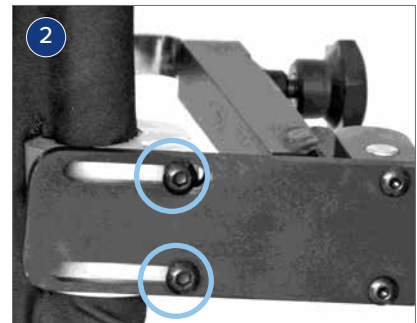
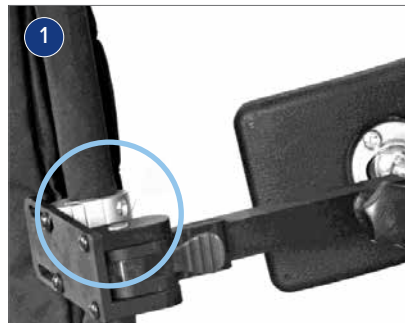

12.13 DRUM BRAKES FOR REAR WHEELS

DESCRIPTION	COMPATIBLE WITH					
	EVOKE 2	EVOKE 2 JNR	REHAB RX JNR	REHAB RX	REHAB RS	ASSIST 2
Rear Wheels w/ Drum Brakes Kit – 16in	–	●	●	●	●	–
Rear Wheels w/ Drum Brakes Kit – 20in	–	●	○	●	●	–
Rear Wheels w/ Drum Brakes Kit – 24in	●	–	–	○	○	●

○ – Comes as Standard Feature

Carton Contents

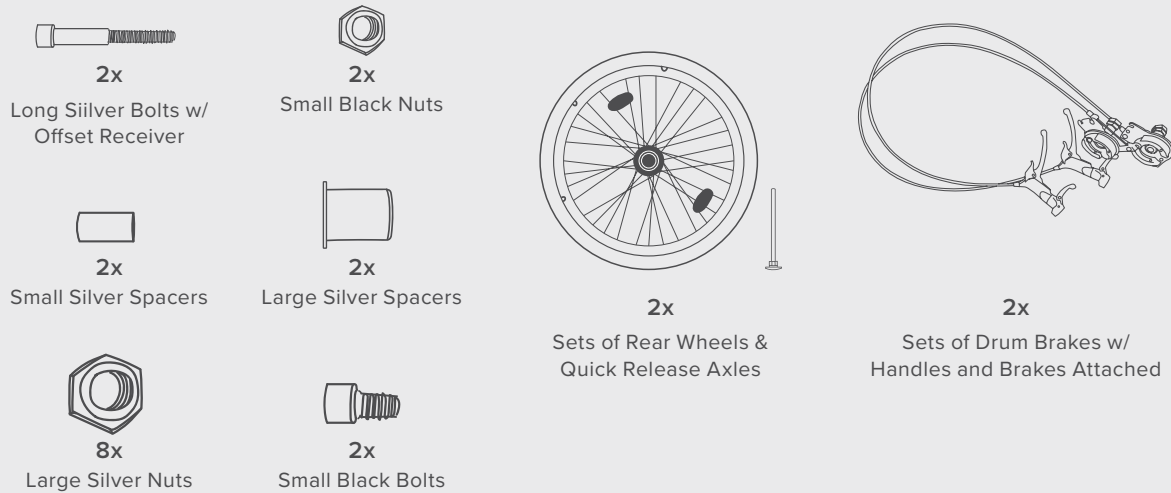

Removing Camber Kit

- 1 Remove quick release axle from wheelchair by pushing in spring button and pulling wheel outwards.
- 2 Lay the wheelchair on its side, remove camber kit from wheelchair frame using a 24mm spanner.

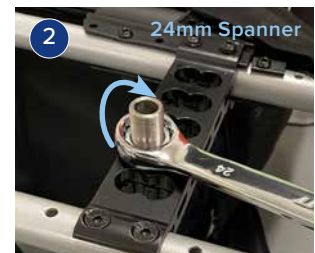
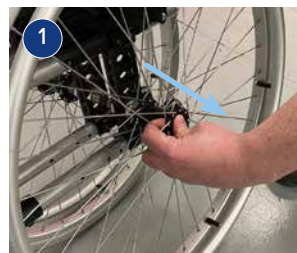

Installing Drum Brakes

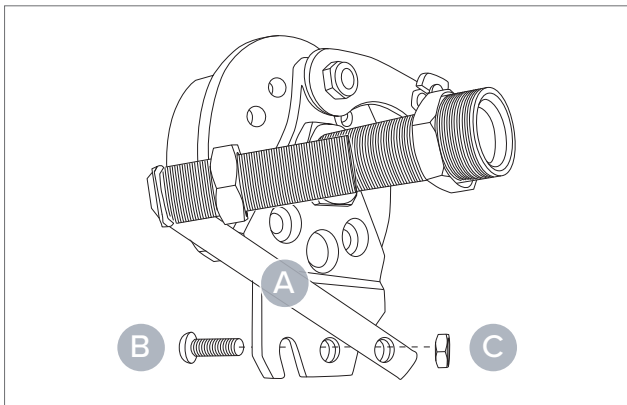

- 3 Install long silver bolt **A** onto brake kit and secure with small black nut and bolt **B** , **C** with 4mm allen key and 10mm spanner
- 4 Ensure the direction of the brake kit is facing upwards towards the top of the wheelchair.

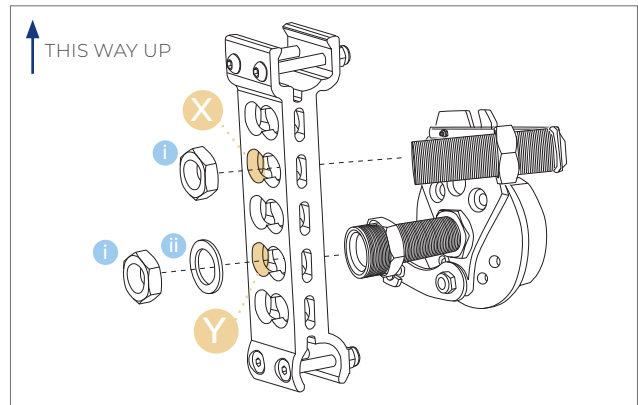

- 5 Slide drum brake kit bolts through holes **X** and **Y**
- 6 Stand wheelchair back onto it's wheels (from side lying position) ensuring cable pin stays pointing towards the top of the wheelchair.
- 7 Mount hardware **i** **ii** on bolts on drum brake kit and drum brake. Secure in place with 24mm spanner.

Installing Hand Brakes

- 1 Mount hand brake to wheelchair handle & fasten in place with a 4mm Allen key.
- 2 Fasten wheel to wheelchair by locking in place with the quick release axle provided in the box.
- 3 Repeat steps 1 to 8 for the other side.

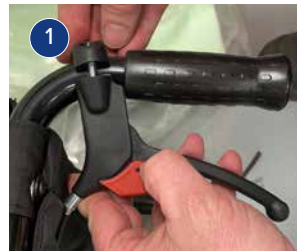

Adjusting Brake Strength

If brakes require tightening or loosening, follow below steps.

- 1 Remove wheel and quick release axle from wheelchair, slide out brake cable.
- 2 Adjust brake strength: Tighten (Clockwise) & Loosen (Anti-Clockwise).
- 3 Reposition brake cable & wheel and lock into place with quick release axle.

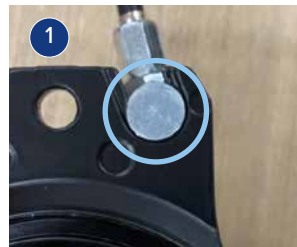

13. AMPUTEE SETTING ADJUSTMENT

Tools and Components Required:

- Part Number: WCA848260 (Supplied with wheelchair)
- 2 x screws
- 2 x nuts
- 2 x washers
- 1 x 4mm Allen key
- 1 x 10mm spanner

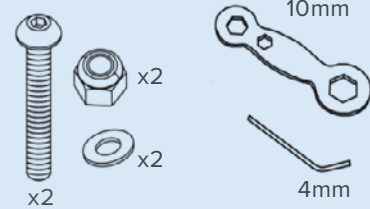
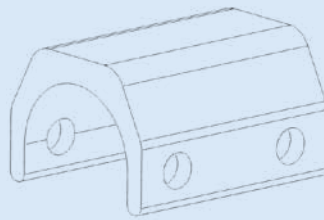

1

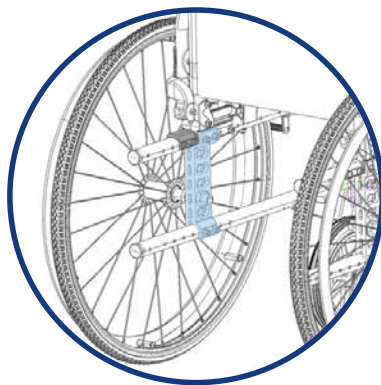

Original Position



WCA848260

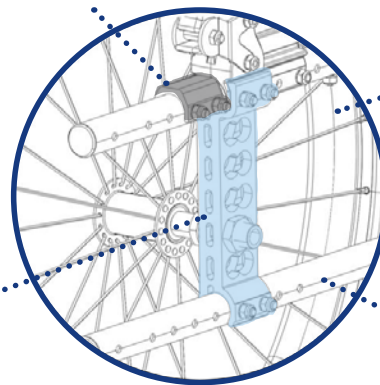

Detail

2 Detach wheel off the frame.

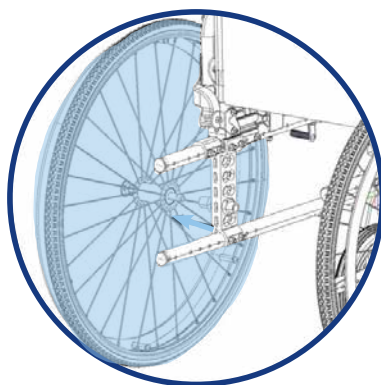

3 a Loosen fastener.
b Move the rear axle mounting plate backward.

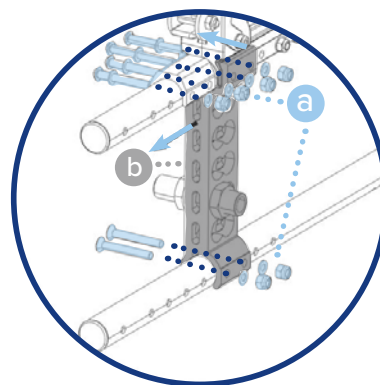

- 4 Tighten the 2 long bolts in the new position, then the 2 short bolts in original position.

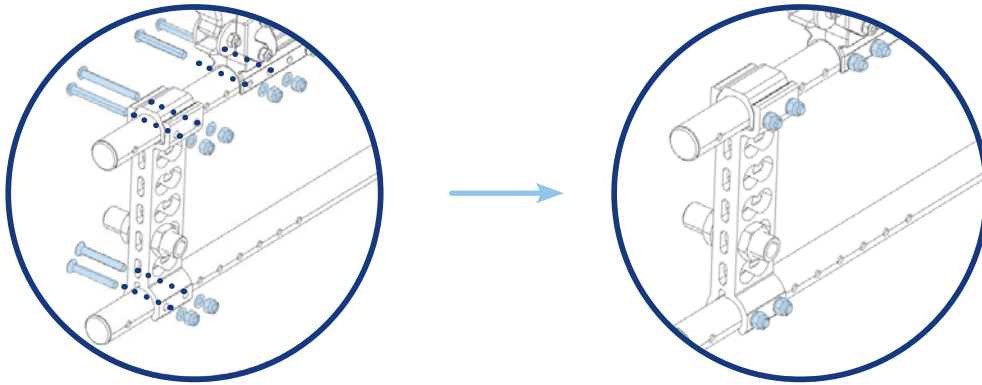

- 5 Attach rear wheel back.

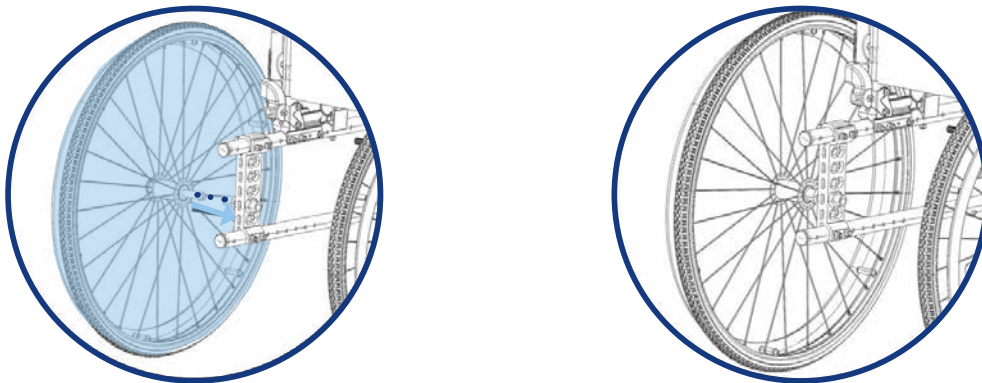

Before

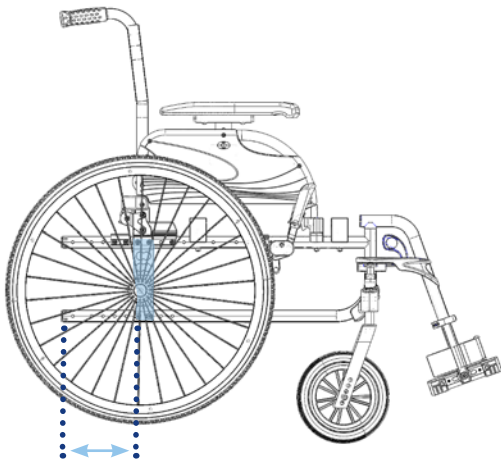

After Rear wheel fitment has been moved to shift the centre of gravity backward.

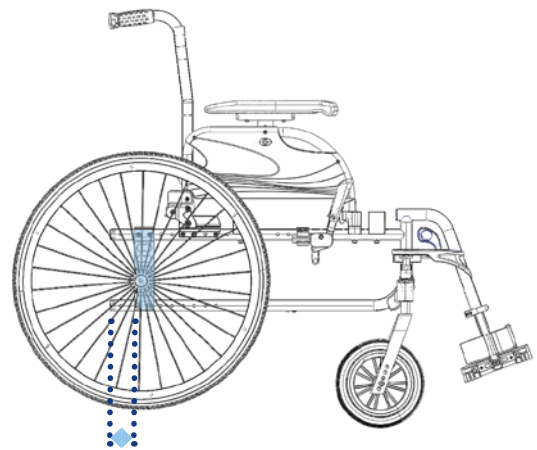

14. TROUBLESHOOTING

Wheelchair is steering/pulling to one side	<p>Ensure rear wheel quick-release axles are locked to securely in place. This can be checked by raising the rear wheels off the ground and pulling gently outward at the wheel hub. When locked in place the locking balls should be visible at the inner end of the axle sleeve.</p> <p>Make sure the end user is able to evenly distribute his/her weight on the wheelchair.</p> <p>Make sure each wheel rotate freely</p>
Wheelchair is moving slowly	<p>Make sure the rear wheels are attached correctly to the frame.</p> <p>Remove any hair or dirt from castor and rear wheel axles.</p> <p>Make sure there is not too much weight applied to the castors, otherwise adjust the centre of gravity.</p> <p>Ensure user clothing is not interfering with movement of the rear wheels.</p> <p>Ensure both brakes are disengaged.</p>
Wheelchair does not turn smoothly	<p>Make sure the front fork bolts are not over tightened which can restrict front castor wheel rotation.</p> <p>Remove any hair or dirt from castor axles.</p> <p>Ensure both brakes are disengaged.</p>
Brakes are not working properly	<p>Check distance between tyres and brake foot is sufficient such that the requisite amount of force can be applied to the tyre surface to stop it moving when the brake is in the engaged position.</p>
Wheelchair cannot be opened or folded easily	<p>Clean the crossbar under the seat and apply some grease.</p> <p>Check that nothing has become lodged under the seat or in and around the cross bar mechanism.</p> <p>Check foot plates are folded up.</p>

NOTE: Correct adjustment of the wheelchair is essential for the successful and safe use of this product.

NOTE: Should assistance be required, contact Aidacare.

15. CARE & MAINTENANCE

MAINTENANCE SCHEDULE

Weekly	Check brakes are functioning properly Check all fastenings such as nuts, bolts and hinges are fastened correctly and functioning normally
Periodically	Check for signs of wear on front castors Check for signs of wear on rear tyres
Yearly	Service to be completed by authorised Aspire service agent
Serviceable Components	Wheels & Tyres Forks Axles Armrest receivers Seat sling Footrest mounts Footplates Armrest Pads

15.1 CARE FOR YOUR CHAIR

- Check tyre condition at least twice per month.
- Check that rear wheel spokes are not loose. Loose wheel spokes can reduce the strength of the rims and must be safely adjusted by a qualified technician.
- Always keep rear wheel axles clean and free from dirt and hair build up.
- Brakes should be checked regularly.

15.2 CLEANING INSTRUCTIONS

- Clean the wheelchair regularly with a damp cloth
- Use a mild washing agent and warm water for excess dirt build-up
- **DO NOT** use harsh abrasive or bleach-based agents which may cause damage or discolouration. **DO NOT** use the wheelchair if damages are found on the seat or backrest upholstery.
- Dry with a soft cloth

Should you have any doubts about the correct functioning of the wheelchair or any of its components, please contact Aidacare.

16. WARRANTY

Aspire Manual Wheelchairs come with a 2 year warranty on the frame and a 1 year warranty on all components. Please keep purchase invoice as proof of warranty commencement.

1 YEAR WARRANTY
Components

2 YEARS WARRANTY
Frame

Please keep purchase invoice as proof of warranty commencement.

This product carries a warranty that varies by component part. The frame and cross frame carry a 2-year warranty, and all other components except consumables (armrest pads, tyres, castors, and upholstery) carry a 1-year warranty. Consumable parts (armrest pads, tyres, castors and upholstery) carry a 1 year warranty against manufacturer defect only, and do not cover wear and tear through use.

For further information contact **Aidacare**.

17. COMPLIANCE

This Wheelchair range is manufactured in ISO compliant production facilities in P.R China to strict quality control standards.

Aspire wheelchairs are manufactured and independently tested to the market relevant compliance standards.

Labels on the wheelchair address compliance requirements and users should familiarise themselves with these prior to use.

18. SERVICE MAINTENANCE & CUSTOMISATION

For all enquiries please contact your local Aidacare branch

18.1 SPARE PARTS

Aidacare stock replacement parts for the Aspire wheelchair range. All replacement of parts should be completed by Aidacare or authorised Aspire service technician. The term parts includes but is not limited to: tyres, brakes, armrests, footrests and upholstery.

A complete parts list is available upon request.

18.2 CUSTOMISATION AND MODIFICATION

All wheelchair customisation, modifications and or alterations made to this product are considered as “custom” changes. These may cause the product to no longer meet safety standards and should be considered prior to commencement.

Any customisation or modification of the wheelchair is not warranted by Aidacare and will void warranty.

19. RECYCLING INFORMATION

Aspire Evoke Wheelchairs are made from metal and plastic components. The chair can be recycled via standard processes in your city of use.

20. MANUFACTURER, EU REPRESENTATIVE & IMPORTER DETAILS

If you have any questions, you can contact:



Manufacturer:

Aidacare Pty Ltd

ABN 40 134 398 833

Building 3A, 1 Moorebank Avenue, Moorebank NSW 2170 Australia

1300 133 120 | product@aidacare.com.au

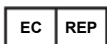

EU Representative:

European Healthcare & Device Solutions (Ireland) Ltd

Stratton House, Bishopstown Road, Cork T12 Y9TC Ireland

info@europeandevicesolutions.eu



Importer:

Aidacare Ltd

Registration 13785408

Arcadia House, Maritime Walk, Ocean Village,

Southampton SO14 3TL United Kingdom

01622 541235 | info@aidacare.co.uk

AIDACARE PTY LTD

Building 3A, 1 Moorebank Avenue,
Moorebank NSW 2170
Australia

1300 133 120 | aidacare.com.au

AIDACARE LIMITED

Arcadia House, Maritime Walk,
Ocean Village, Southampton SO14 3TL
United Kingdom

01622 541235 | aidacare.co.uk

MADE IN PRC

230426

